



Klapblok / Snatch Block

Eigenschappen

- » Stalen behuizing.
- » Snelle kabelinstallatie door scharnierende constructie.
- » Met draaibare lasthaak.
- » Permanent gesmeerde bout lager.
- » Veiligheidsontwerp: Zijplaat kan niet onder belasting worden geopend.
- » Voldoet aan de Machinerichtlijn 2006/42/EG. Geleverd met testcertificaat, CE-conformiteitsverklaring en gebruiksaanwijzing.

Features

- » Steel body.
- » Quick rope installation due to hinged design.
- » With swivel load hook.
- » Permanently lubricated pin bearing.
- » Safety design: Side plate cannot be opened under load.
- » Complies with the Machinery Directive 2006/42/EC. Supplied with test certificate, CE declaration of conformity and operating instructions.

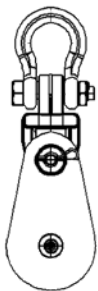

op aanvraag met harpsluiting /
on request with shackle

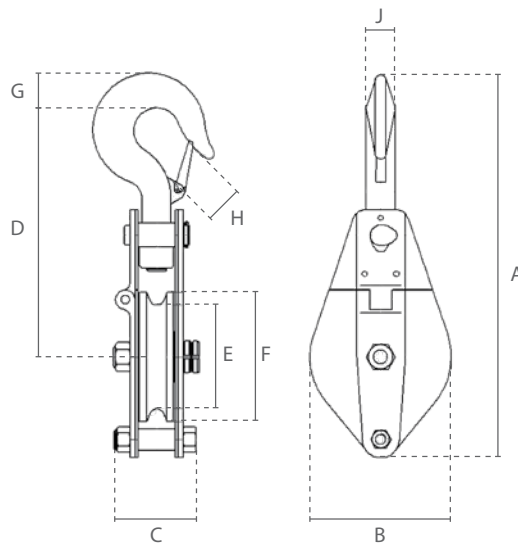

Specificaties / Specifications			
Artikel nummer	Capaciteit	Kabel diameter	Netto gewicht
Article code	Capacity	Cable diameter	Net weight
	ton	mm	kg
SG.0.KB.0500	0.5	5	2.3
SG.0.KB.1000	1	7	3.8
SG.0.KB.2000	2	13	7.3
SG.0.KB.3200	3.2	15	13.5
SG.0.KB.6400	6.4	18	22

Specificaties / Specifications	
Bedrijfstemperatuur / Operating temperature	-20°C - +40°C

Afmetingen / Dimensions									
Capaciteit / Capacity	A	B	C	D	E	F	G	H	J
ton									
0.5	261	99	75	173	75	88	21	19	19
1	310	117	84	205	85	105	23	26	20
2	425	200	92	263	150	190	30	27	24
3.2	496	230	108	295	180	220	40	31	28
6.4	655	270	116	375	260	260	47	42	35